

Gooxi

RMC4124-670-HS



User Manual

Version 1.0

Content

Manual Structure

Foreword

Chapter 1 Chassis Overview

Chapter 2 Easy Installation Instruction

Chapter 3 Chassis Parameters

Foreword

This manual is about the installation and use information of RMC4124-670-HS chassis that provided to professional system integrators and personal computer technicians. The installation and maintenance should be conducted by experienced technicians only.

Gooxi RMC4124-670-HS the fourth generation of server chassis is designed based on standard 2U server and can be assembled into common computing server, storage server, Internet bar server, database server, VOD storage server, HPC server, and so on. The server chassis is different from ordinary desktop chassis that pays more attention to appearance design, as it focuses on the quality and content. Gooxi RMC4124-670-HS server chassis uses imported first-class SGCC galvanized steel, and possessed with the characteristics of fingerprint resistance, corrosion resistance, heat resistance, heat transfer and thermal reflectivity, formability as well as weldability.

In addition, taking into account the higher stability requirements of the server during usage, Gooxi RMC4124-670-HS server chassis has excellent heat dispersion. To be specific, the heat dissipation channel is reasonably designed, which can take away a large amount of heat in the chassis to ensure the stable operation of the server.

The scalability is an important factor to determine whether the server chassis design is reasonable. Gooxi RMC4124-670-HS server chassis has stronger scalability than ordinary chassis, such as: hard disk expander, peripheral expander, etc.

Chapter 1 Chassis Overview

1.1 Chassis Structure

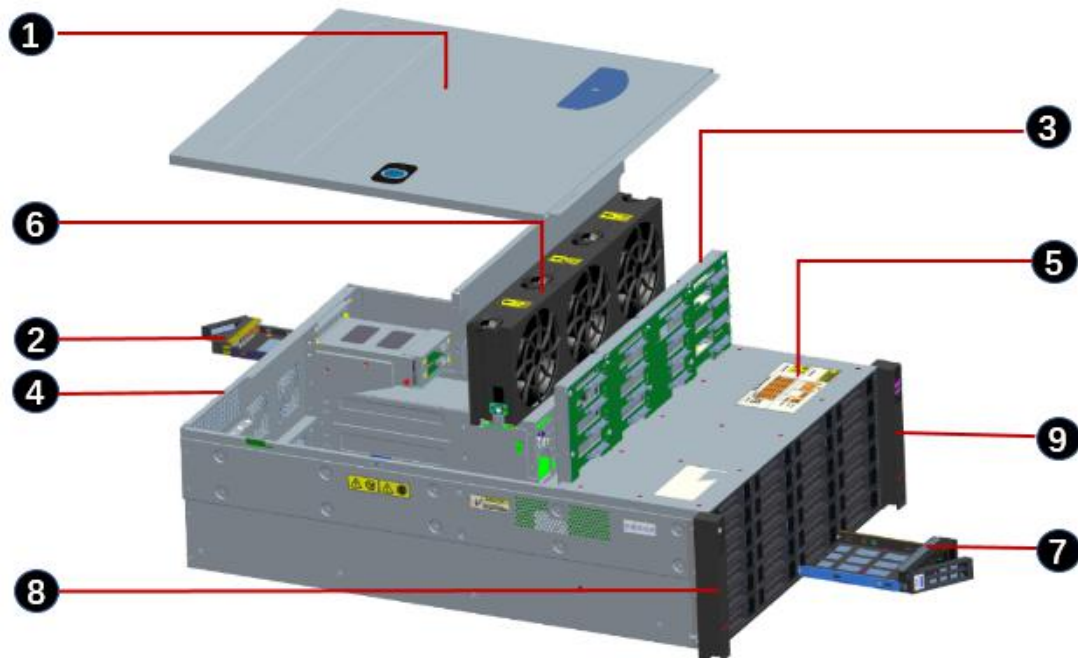

- (1) Top cover
- (2) 2.5-inch hard disk box
- (3) Backplane
- (4) Rear window
- (5) Hard disk module
- (6) Fan
- (7) 3.5-inch hard disk box
- (8) Left-side ear
- (9) Right-side ear

1.2 Rear Window Construction

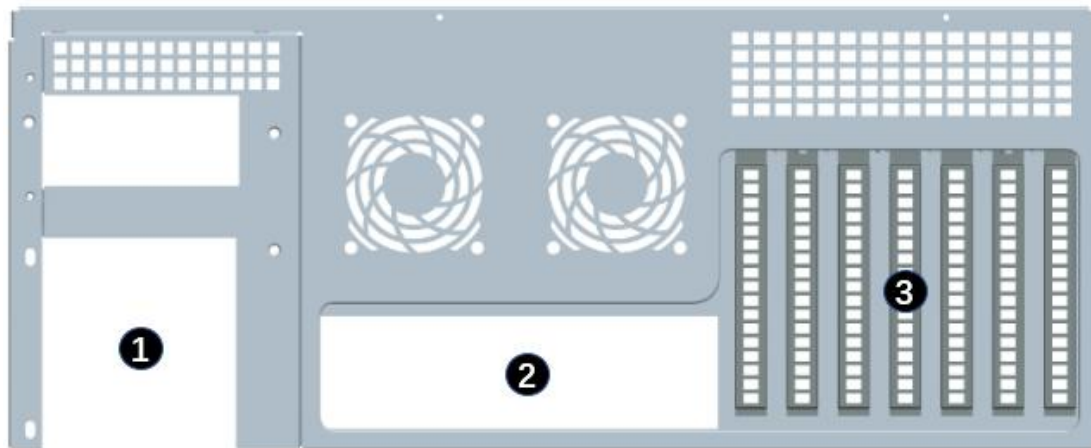

- ① Power site
- ② I/O washer position
- ③ Expansion slot

1.3 Materials Package

- 96 pieces of #6-32*5mm countersunk screws are used for fixing hard disks.
- 10 pieces of active studs with the total height of 8mm are used to install the motherboard.
- 16 pieces of #6-32*6mm cross recessed pan head screws are used for fastening the motherboard and power supply.
- 0~23 SAS - label.
- One 100 * 120 * 0.045mm PE valve bag.

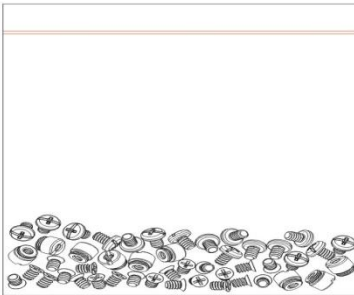

1.4 Chassis View

Front view:



Rear view:



1.5 Related Indicators of Chassis Panel

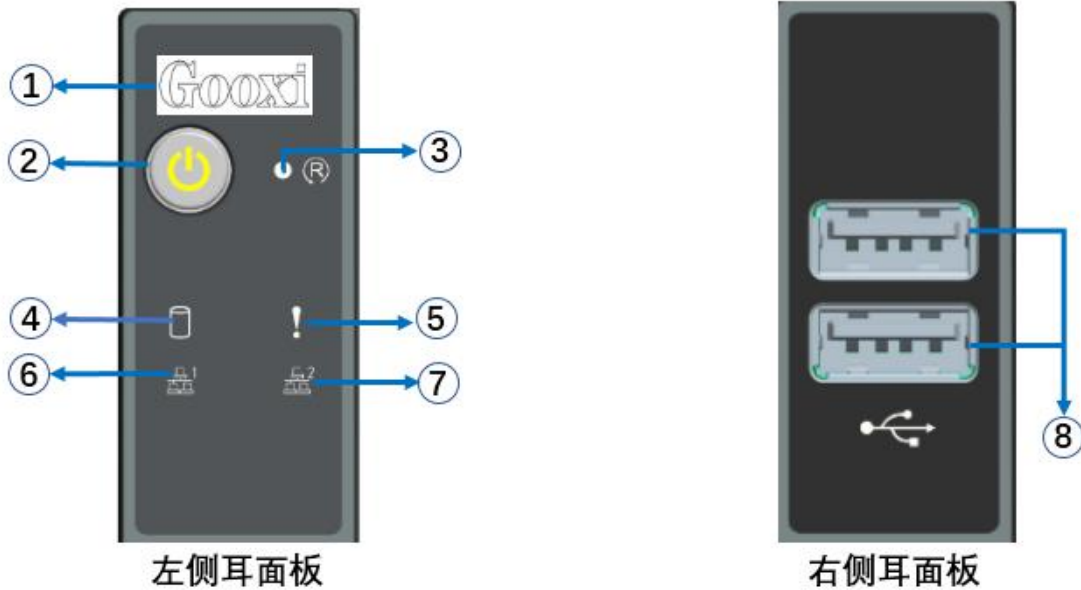

The above picture shows the front panel buttons and LED indicators; each button or indicator light has its own function and status description that are described in the following table:

LED Status Description			
No.	Picture	LED Appearance	Description
①		-	LOGO label (labeling or customized acrylic label)
②		The green light is on	The device is on
③		Reset	The button is used to restart the server
④		The green light flashes	The system is running normally
⑤		The yellow light is on	Alarm indication, including system alarm, fan alarm, power alarm, etc.; the specific can be viewed through IPMI management software
⑥		The green light is on	Internet access 1 connection is normal
⑦		The green light is on	Internet access 2 connection is normal
⑧		USB interface	2*USB2.0 interface

1.6 Introduction to Hard Disk Indicator

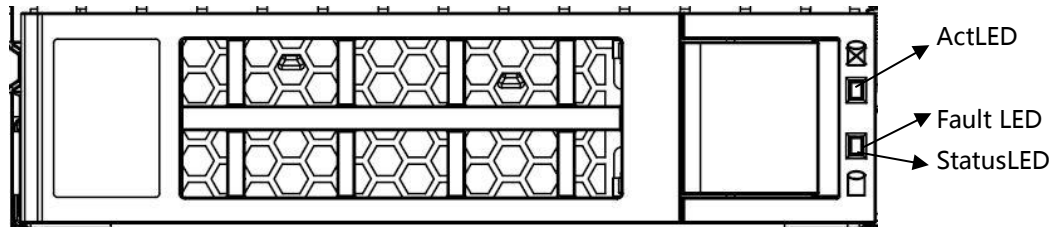

- 1、 Act LED
- 2、 FaultLED
- 3、 StatusLED
- 4、 LED description is as follows:

Function	Act LED	Fault LED	Status LED
Hard disk at site	ON	OFF	OFF
Hard disk activity	Flash 4Hz/s	OFF	OFF
Hard disk location	ON	Flash 4Hz/s	OFF
Hard disk fault	ON	OFF	ON
RAID reconstruction	ON	OFF	Flash 1Hz/s

1.7 Brief Introduction to Backplane

The standard configuration of Gooxi backplane model is RMC4124-BP-12G, and the specific description is as follows:

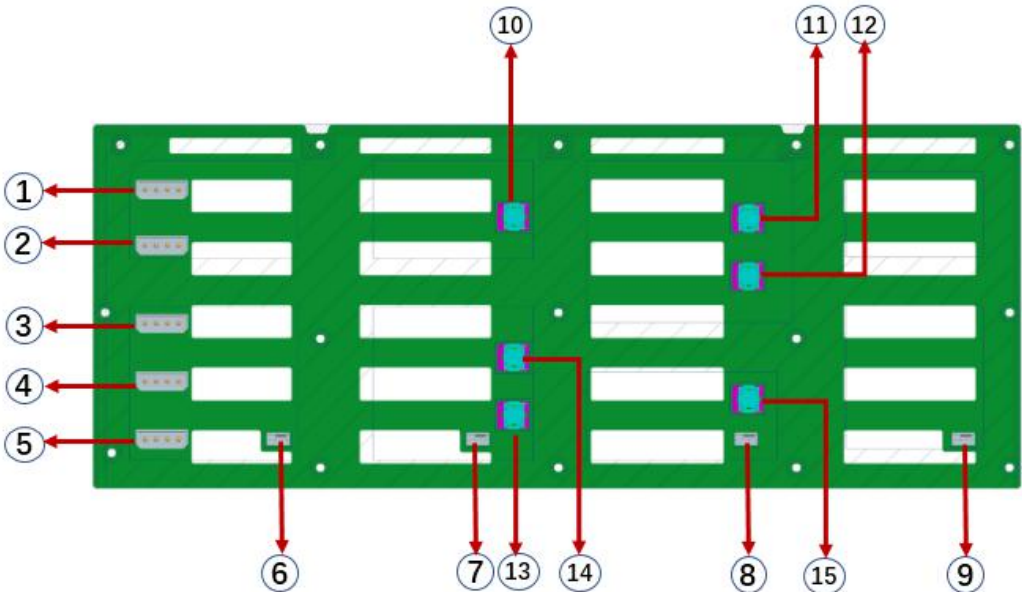

RMC4124-BP-12G			
Corresponding site	Interface / jumper / slot	Corresponding site	Interface / jumper / slot
1、2、3、4、5	5 ATX power input	10、11、12 13、14、15	SFF-8643 12Gb SAS input interface
6、7、8、9	4 Sockets of 4PIN temperature control fans		

1.8 Introduction to the Output Interface of Backplane Hard Disk



Chapter 2 Easy Installation Instruction

2.1 Introduction to the Disassemble Steps of Gooxi 4124 Chassis Cover

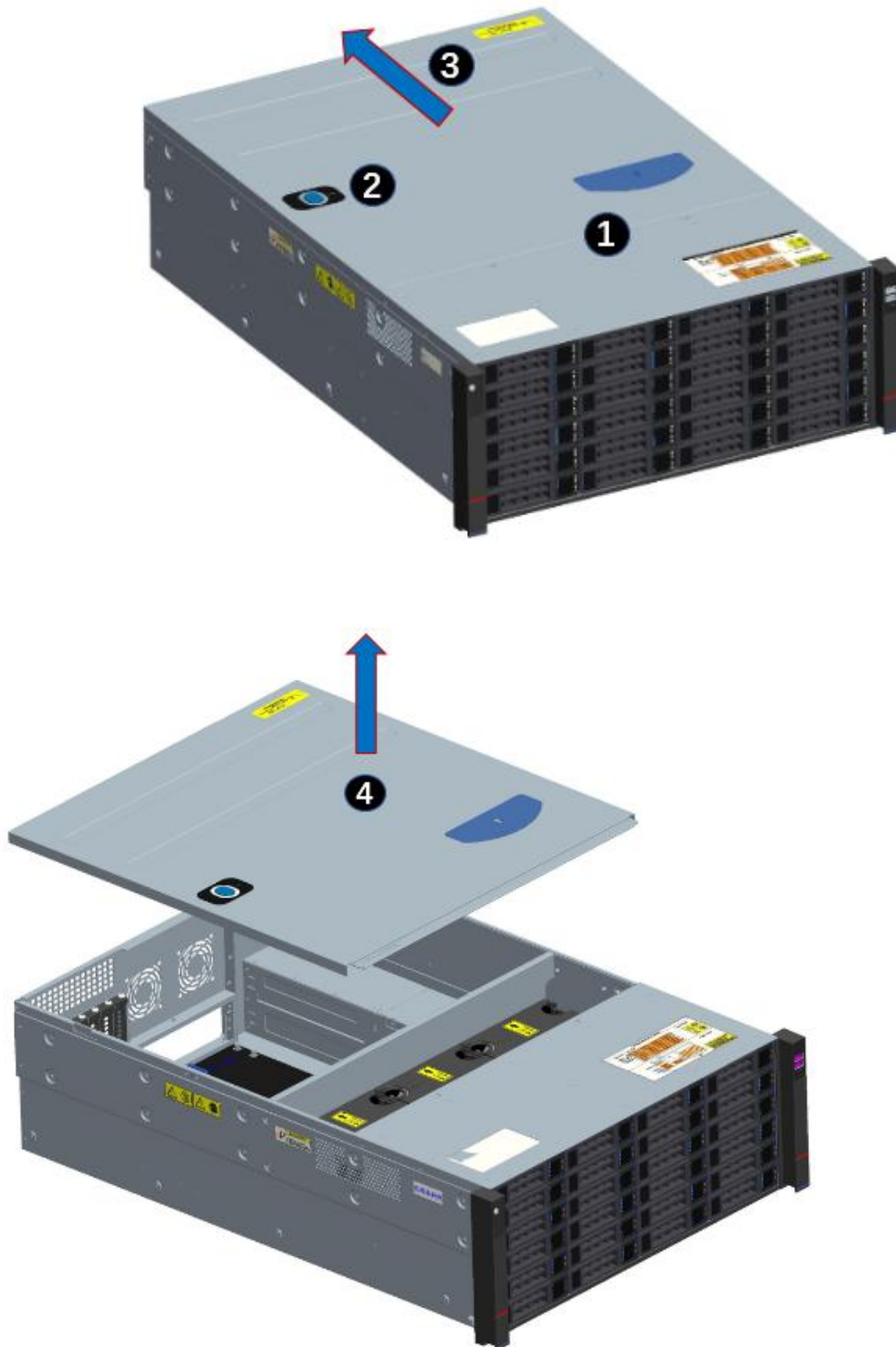

- (1) Unscrew the top cover screws
- (2) Press the button of chassis back cover

- (3) Push the back cover
- (4) Pull the back cover

2.2 Introduction to the Installation Steps of Gooxi4124 Chassis Fan Module

- (1) Install the hot-swappable fan modules into the chassis, respectively.

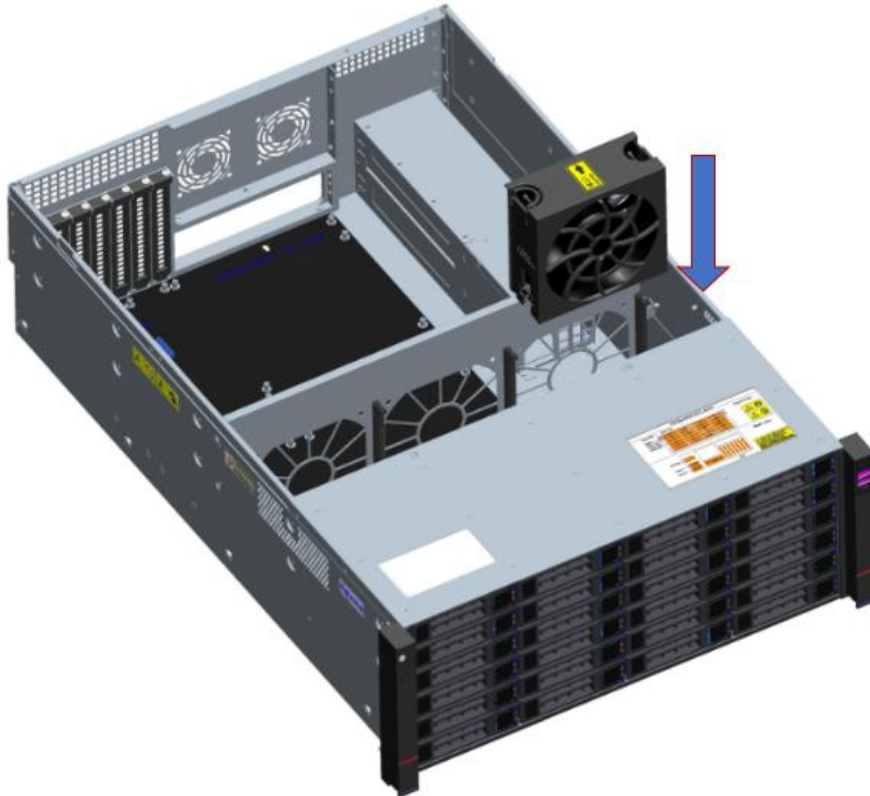

- (1) Finished completion effect of fan module.



(2) Finished completion effect of the last three fan modules.



2.3 Introduction to the Insert and Plug Steps of Gooxi4124 Chassis Hard Disk

(1) Press the button to pull out the hard disk from the hard disk site.



(2) Install the 3.5-inch hard drive to the hard drive bracket according to screw holes, as shown in the figure below.

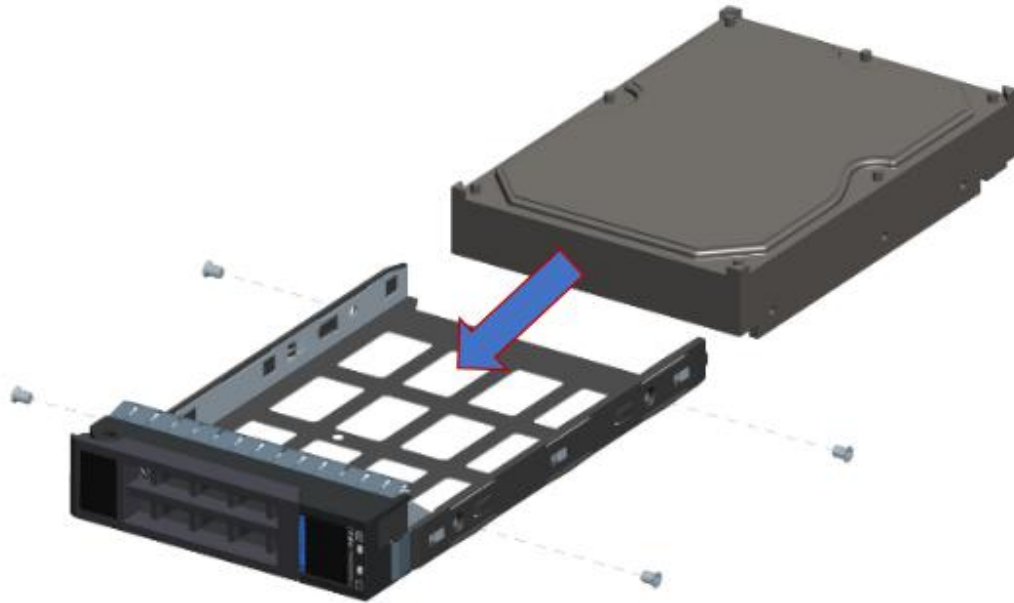

(3) The installed hard disk is shown in the following figure:



(4) Insert hard disk to the chassis, and close the switch. As shown in the following figure.



2.4 Introduction to the Installation Steps of Gooxi4124 Chassis Power Supply

- (1) Place the power supply case to the chassis according to the hole site, as shown in the figure below.

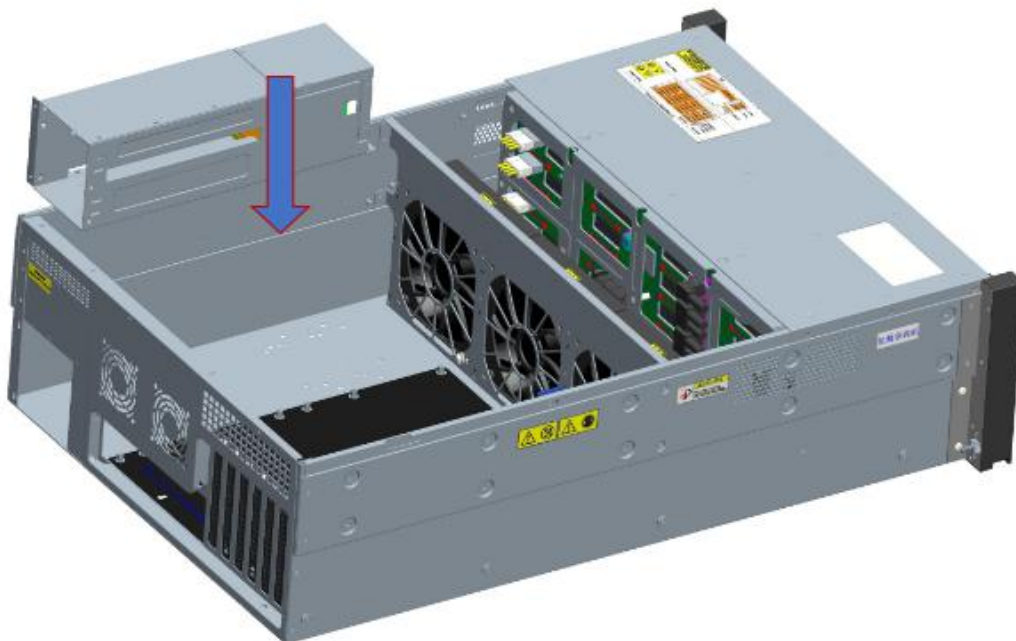

- (2) Fix the power supply bracket, and screw on the screws at the position marked in the figure below.



(3) Insert the hot-swappable power modules PSU1 and PSU2, respectively

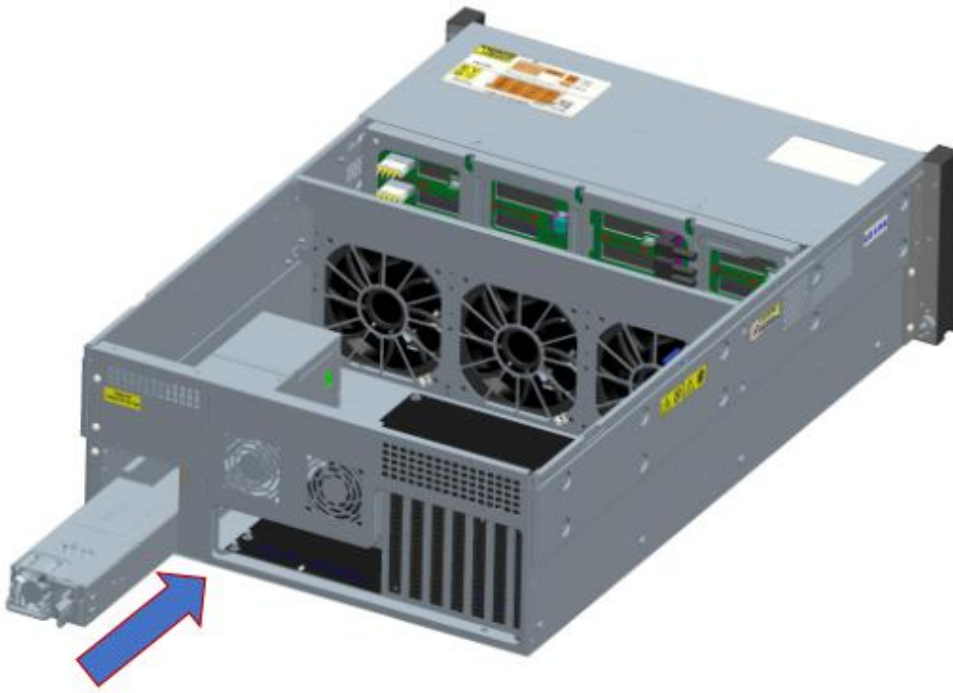

(4)The final installation effect of power supply

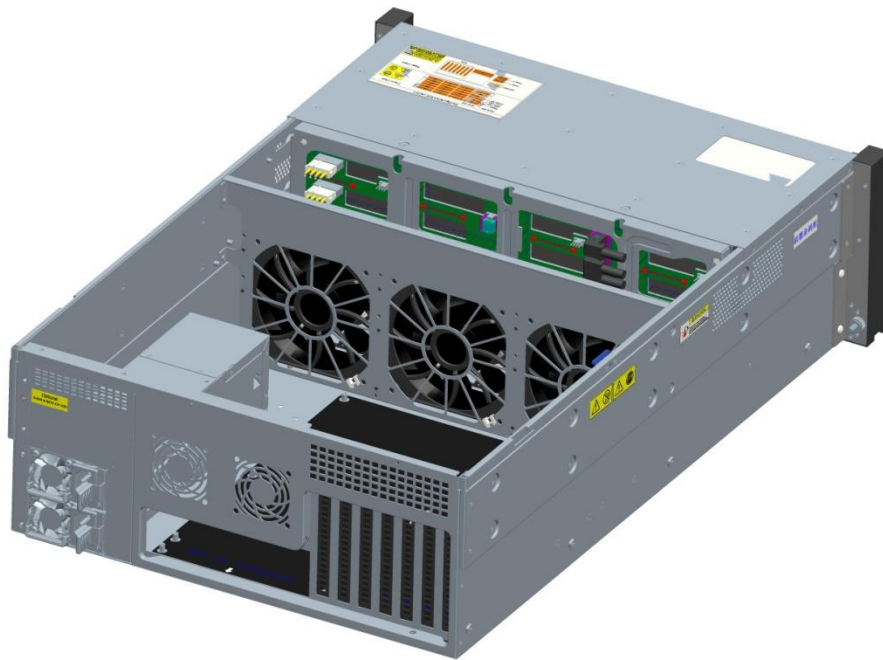

2.5 Introduction to the Installation Steps of Motherboard on Gooxi 4124 Chassis

(1) Open the chassis, and place insulation pad according to the correct orientation. Based on the hole of motherboard screw, motherboard active stud (8mm height) is installed at the corresponding position on the insulation pad. As shown in the figure below: Install Gooxi G1DE-4B dual circuit motherboard corresponding to the base hole site.

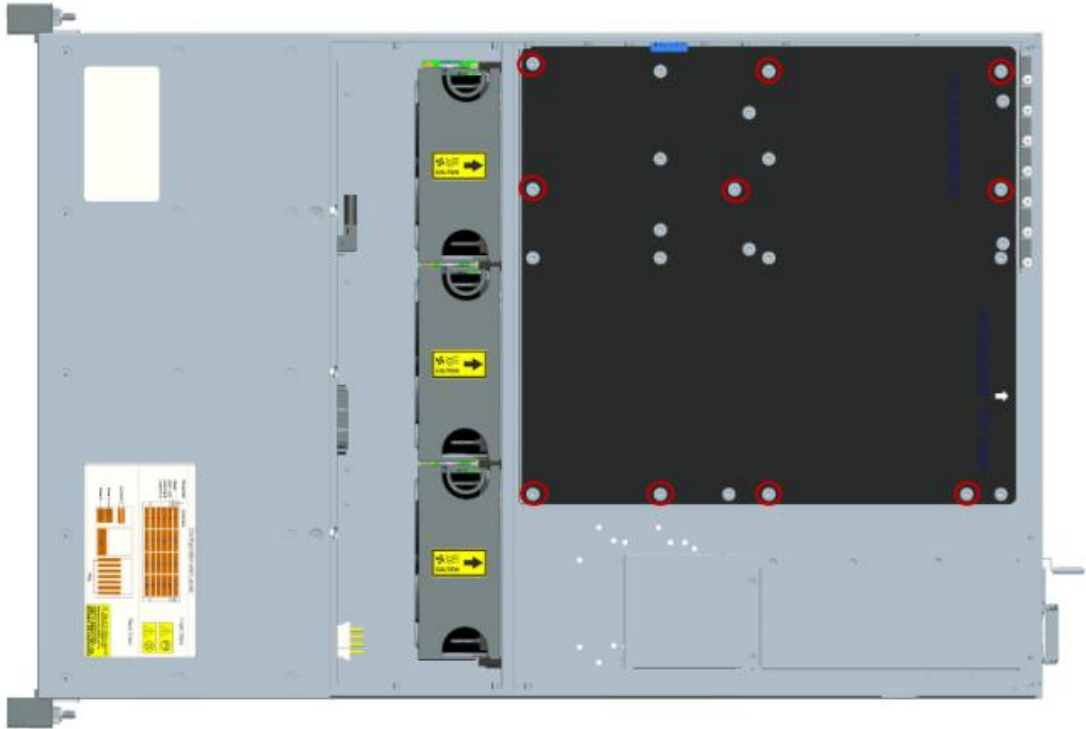

(2) After the motherboard active stud (8mm height) is installed, place the motherboard into the chassis and fasten motherboard screw at the hole site. As shown in the figure below:

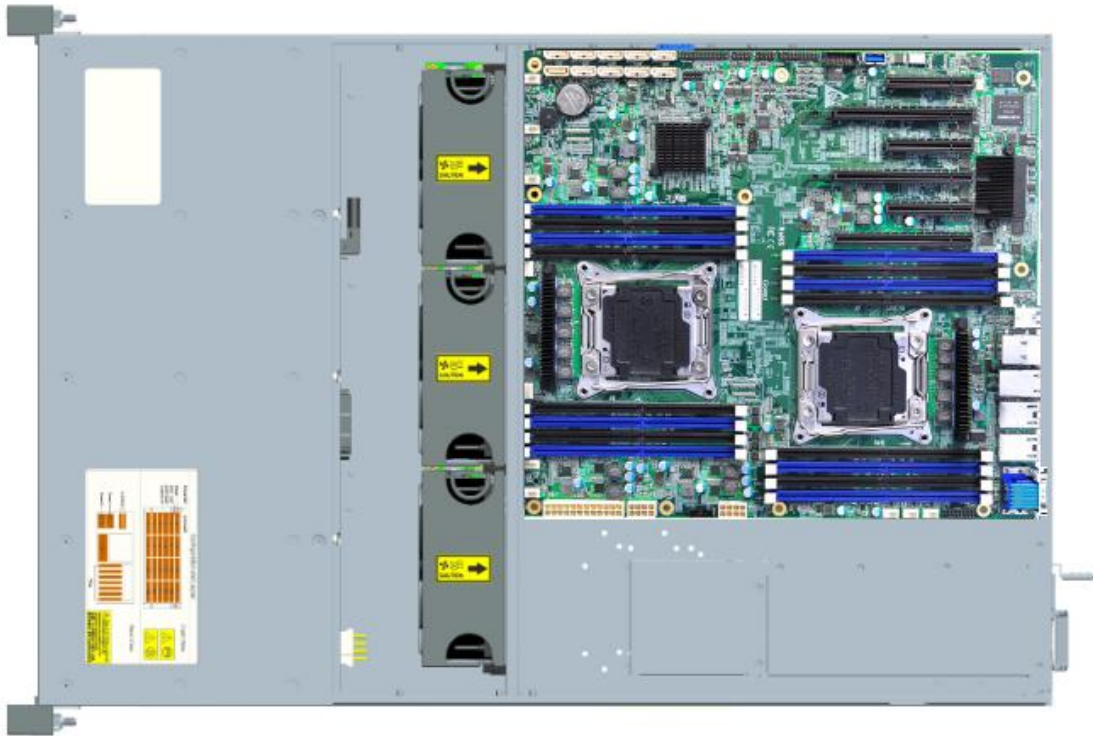

2.6 Introduction to the Installation Steps of Built-in 2.5-inch Hard Drive on Gooxi4124 Chassis

(1) Install the 2.5-inch hard disk on the bracket.

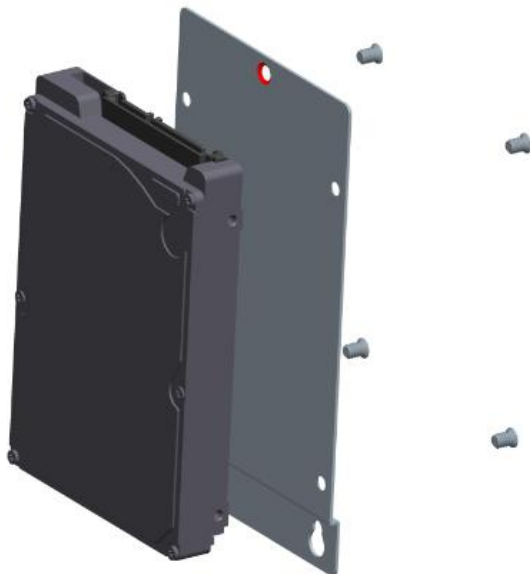

(2) As shown below: Install two 2.5-inch modules on the inside of the chassis

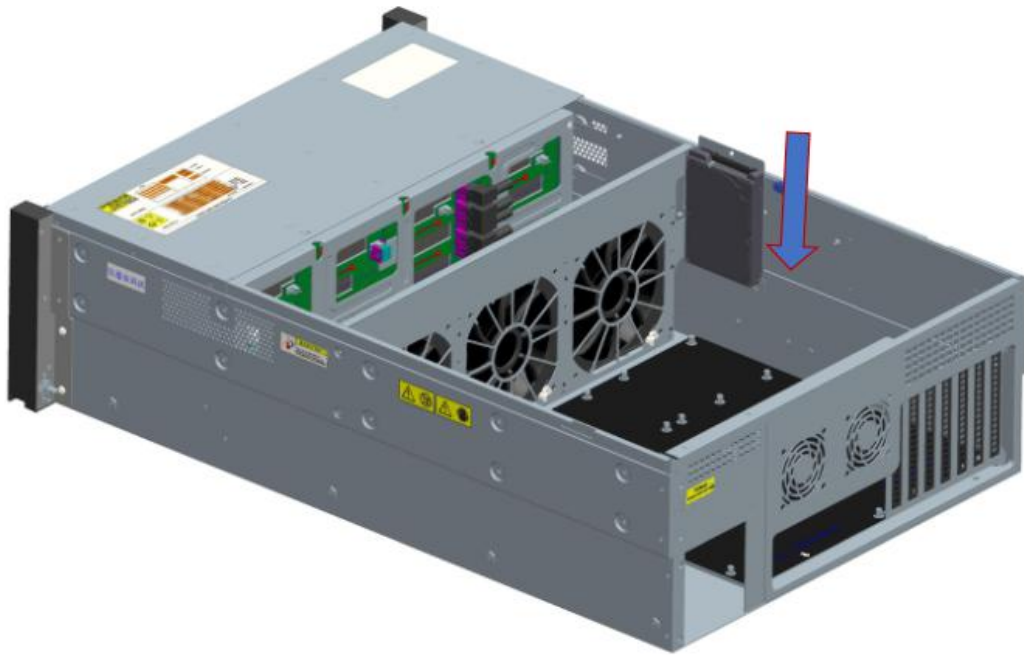

(3) Completed installation effect

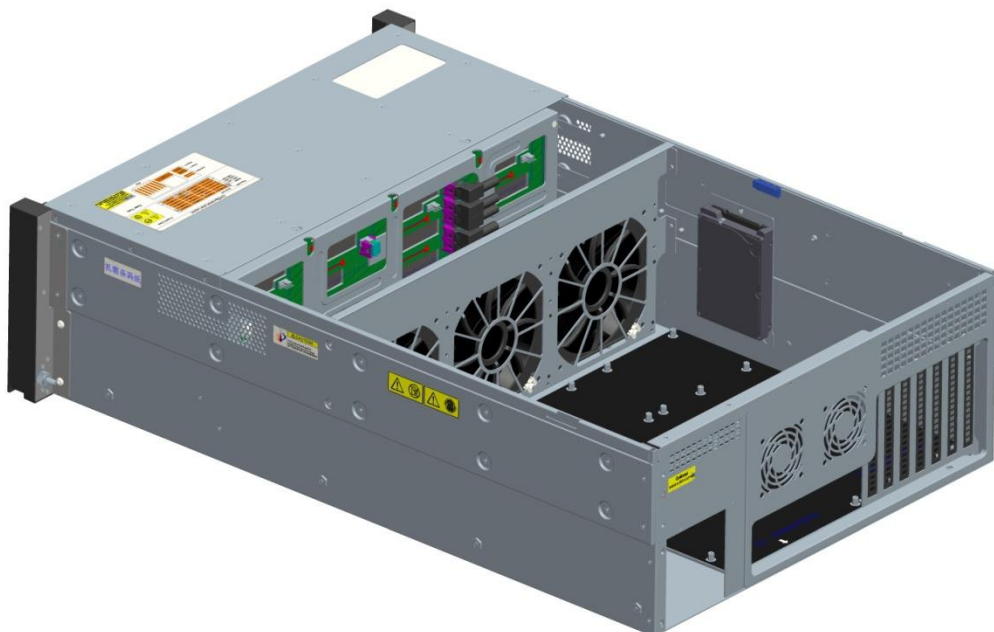

(4) Completed installation effect of two built-in hard disks

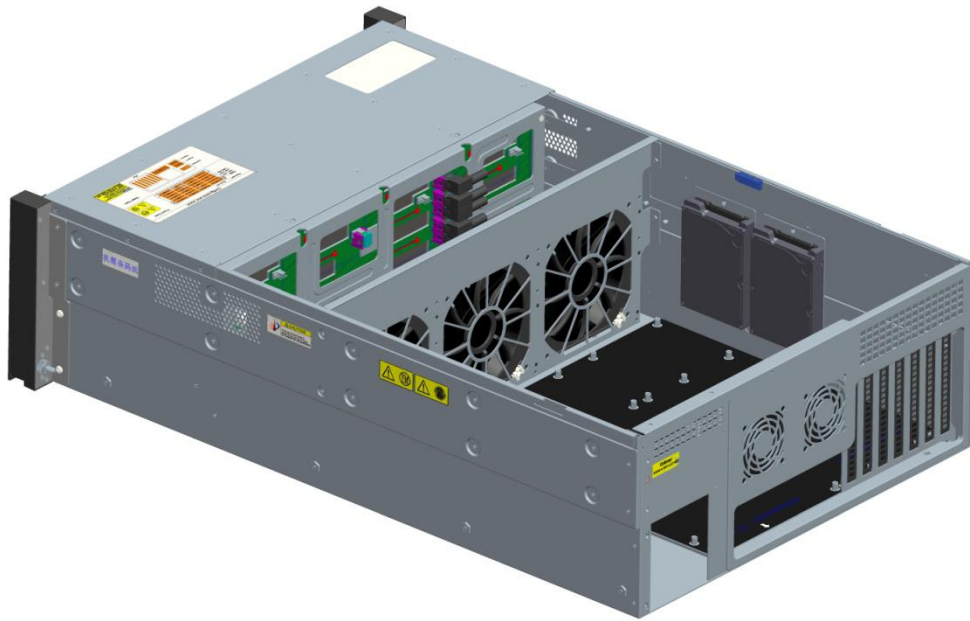

2.7 Introduction to the Installation Steps of Rear Hot-swappable 2.5-inch Hard Drive on Gooxi4124 Chassis

(1) Replace the rear window suite of CRPS power supply case, and it supports the installation of 2.5 modules.

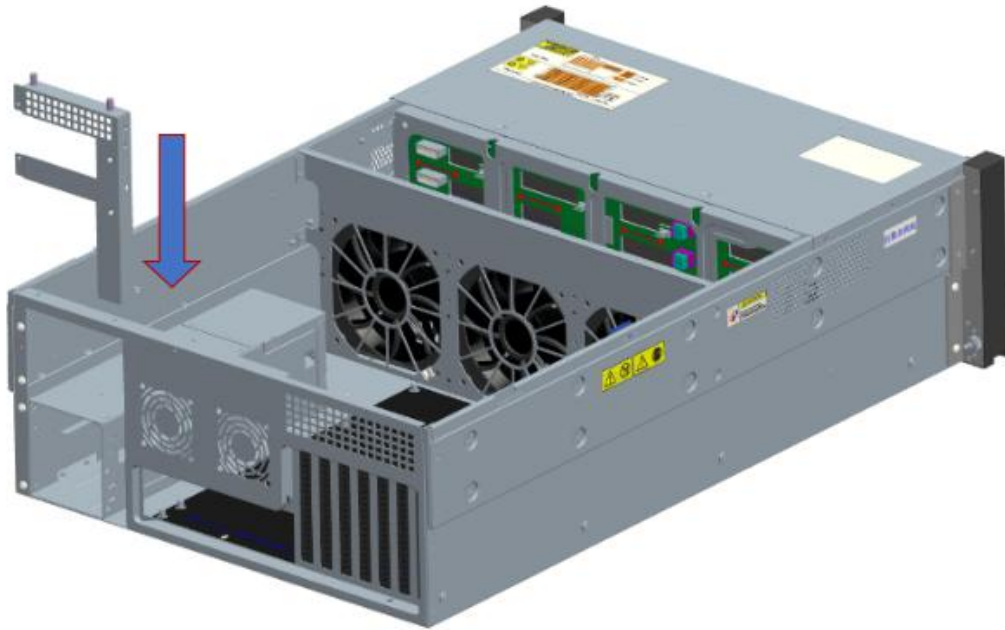

(2) Effect picture of rear window suite after the power is completed.



(3) 2.5-inch hot-swappable hard drive module is installed and locked to the chassis base with a screw, as shown in the figure below:

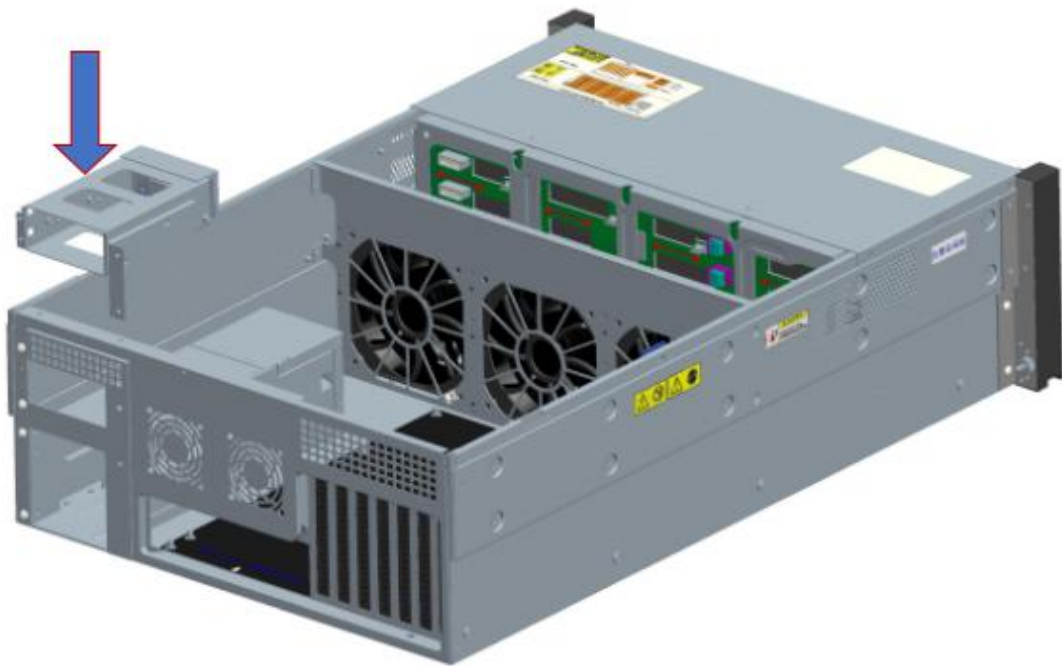

(4) Lock the screws at the rear window position.

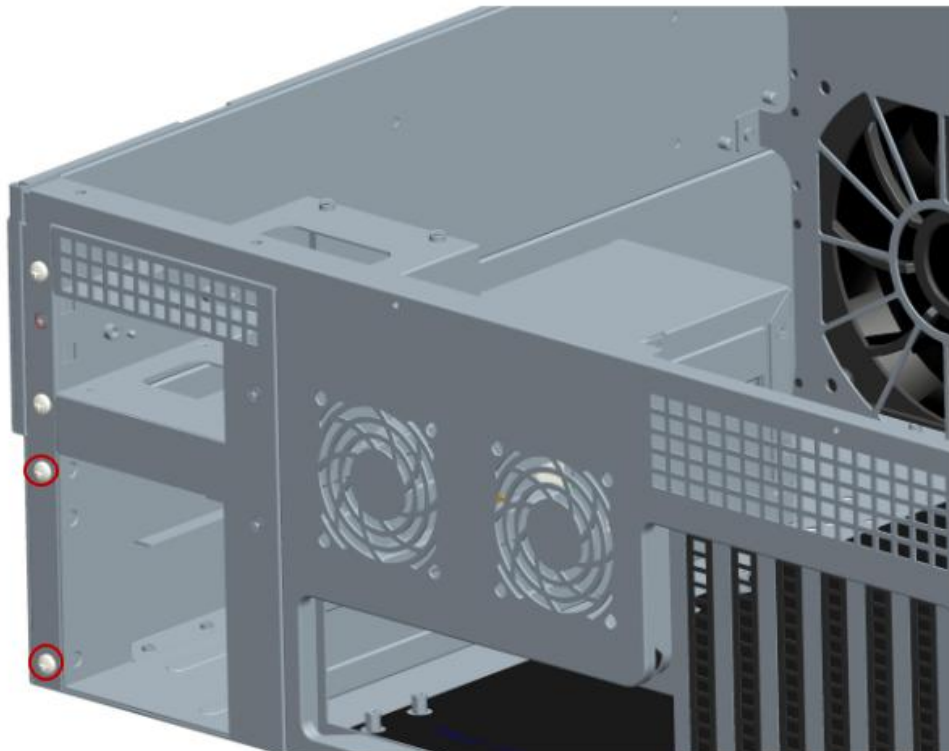

(5) Effect picture of completed installation of 2.5-inch hot-swappable hard drive module

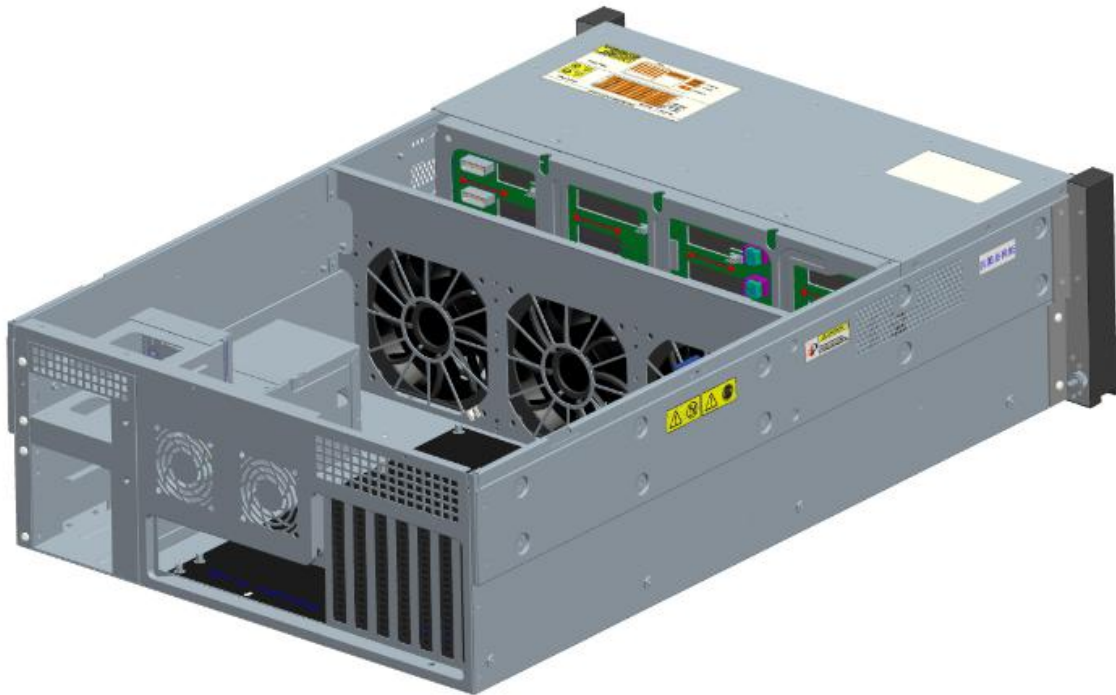

(6) Insert two 2.5-inch hard drives into the hard disk box, respectively

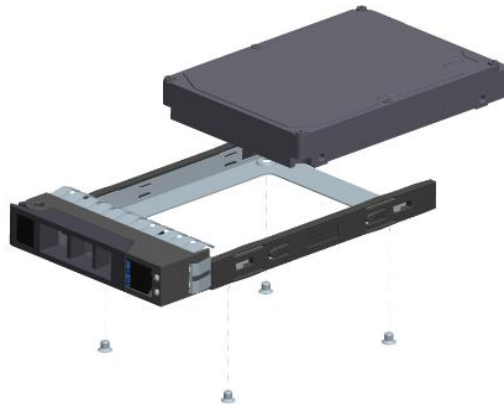

(7) Insert two 2.5-inch hard drives into the rear hard disk module, respectively

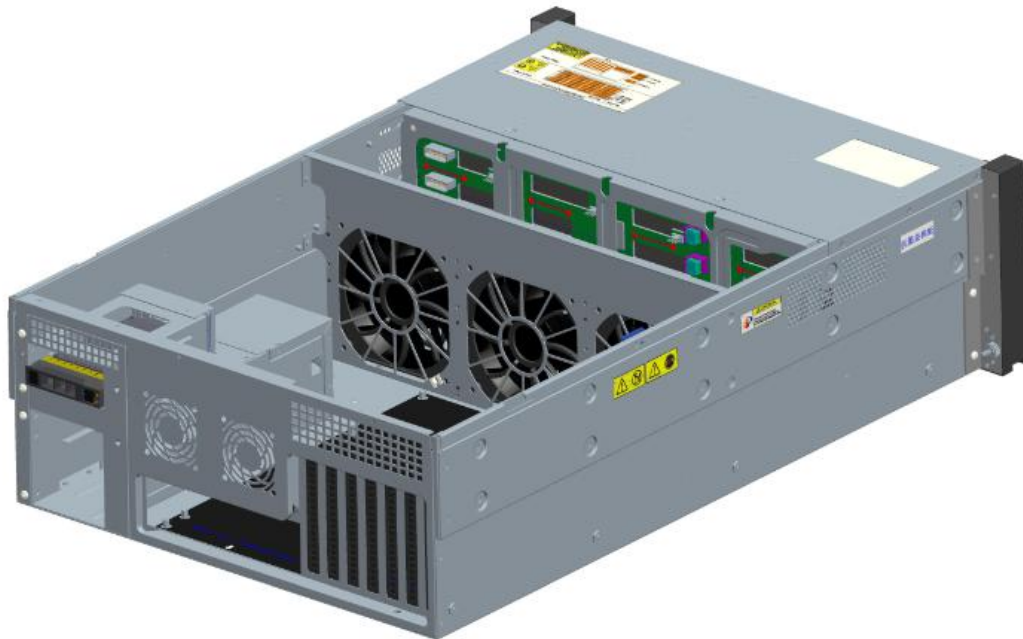
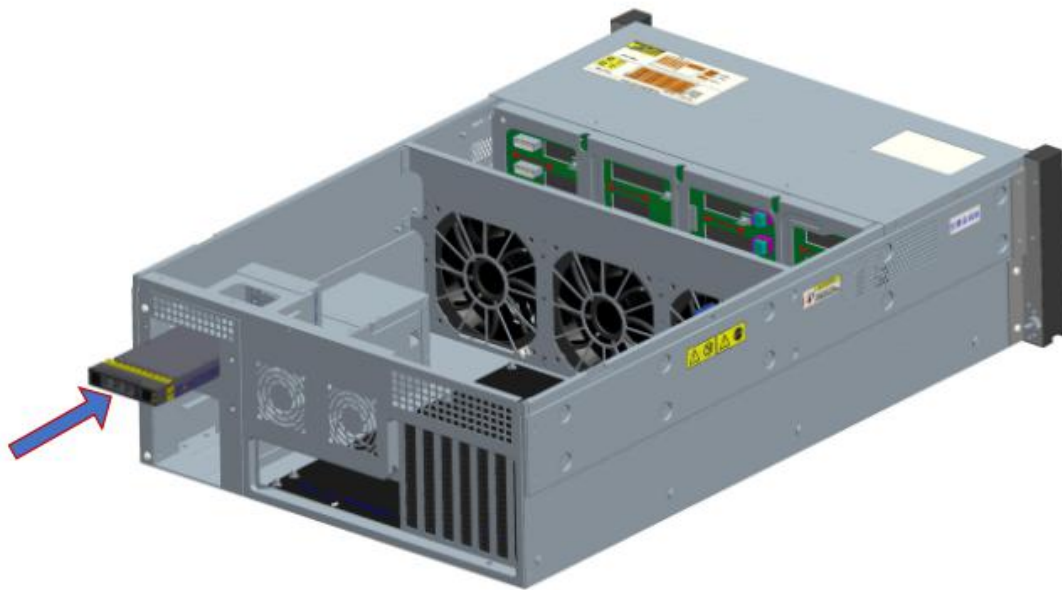

(8)The completed installation effect is as follows

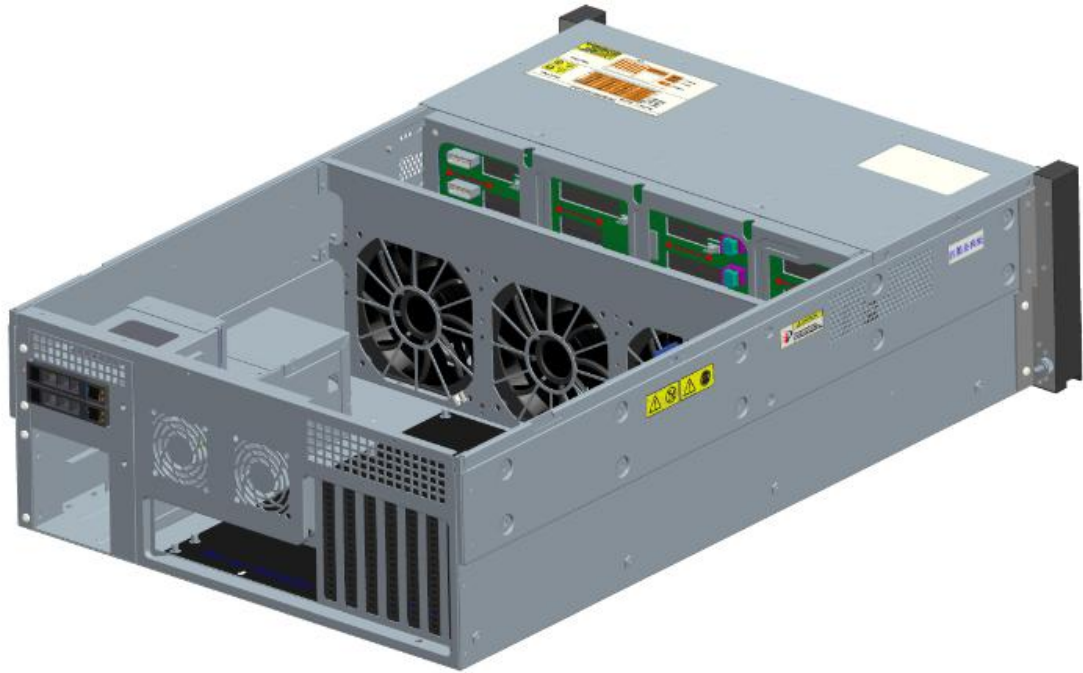

 **Note:** If customer selects two optional 2.5-inch hot-swappable hard drives, then Gooxi-type CRPS power must be equipped with.

Chapter 3 Chassis Parameters

Basic Parameters	
Chassis style	Rack mount
Chassis structure	4U
Applicable motherboard	EEB (12*13) /CEB (12*10.5) /ATX (12*9.5) /Micro ATX
Supported motherboard brands	Gooxi、Intel、ASUS、SuperMicro、TYAN、MSI、GIGABYTE, etc
Power type	Single charge and 1+1 redundant power
Number of supported power supplies	1
SGPIO	Support
Backplane	12Gb/s SAS data backplane
Supported hot-swappable hard drives	Supportive, compatible with SAS and SATA drives
Supported hot-swappable hard fans	Support
Hard driver site	Twenty-four 3.5-inch (or 2.5-inch) hot-swappable hard disk sites; two 2.5 inch built-in non-hot-swappable hard disk sites, and two 2.5-inch rear-built hot-swappable expandable sites (optional)
CD driver site	None
Hard disk shockproof system	Hard disk bracket is designed with EMI shrapnel. The unique shockproof fan design can reduce the resonance between the fan and hard disk without affecting the reading and writing speed of hard disks.
Cooling system	12038 fans of three brands are standard configuration
Windshield	Support
Intelligent control of temperature	7 half-height PCI or PCI-E expansion card sites
Expanded card site	Optional
Apparent Parameters	
Front panel interface	1 on-off key, 1 restart key, 1 fan alarm lamp, 1 hard disk indicator and 2 network indicators
Free screws dismantle	Support
Fixed mode of cabinet	Ordinary
Configuration Parameters	
Product material	Imported SGCC (galvanized steel sheet), ABS panel and punching net
Chassis dimension	670*444*177mm (Depth * width * height)
Chassis weight	18kg
Package dimension	902*591*318mm (Depth * width * height)

Overall gross weight	24KG
Safety certification	CE、FCC、RoHS

Note: This manual is a general instruction of RMC4124-670-HS series. Specific parameters of each type please refer to the chassis detailed parameters.